



Turbo Series 5 User Manual



Contents

1. Safety Precautions.....	3
2. Getting Started	4
2.1 Basic Information	4
2.2 In the Box.....	5
2.4 Installation.....	5
Location.....	5
Clearances.....	6
Airflow.....	7
Waterflow.....	7
Condensation.....	7
Connections.....	7
Plumbing.....	8
Wiring.....	9
Display.....	11
Installation Checklist.....	12
2.4 First Start	13
3. Technical Data	14
3.1 Specifications	14
3.2 Dimensions	15
5. Operation	16
5.1 Controller.....	16
Functions.....	16
5.2 Unit	22
Functions.....	22
6. Maintenance.....	23
6.1 Turbo Unit.....	23
Paint.....	23
Heat Exchangers.....	23
Condensers and Cabinet.....	24
6.2 Display.....	25
Screen.....	25
Case.....	25
6.3 Transportation	25
7. Troubleshooting.....	26

1. Safety Precautions

Ensure you read this manual in full before installing your new Turbo.

Instructions given within this manual must be followed. Failure to do so will result in warranty being voided.

Do not perform any modifications of the unit without approval of iCoolSport.

Never place anything within the minimum clearances that could restrict airflow.



All electrical and plumbing work must be completed by licensed technicians in accordance with all applicable standards and local regulations.



All wiring must be completed in accordance with national wiring regulations.



Warning: Wiring must include an RCBO.



Warning: Wiring must contain an insulation switch that provides contact separation in all poles.



Warning: Unit must be connected to protective earth.



Warning: Do not assist the unit in speeding up the defrost cycle.



Warning: Isolate and disconnect all power before opening unit for servicing.



Warning: Before obtaining access to terminals, all supply circuits must be disconnected.

This appliance is not intended for use by persons (including children) with reduced physical, sensory or mental capabilities, or lack of experience and knowledge, unless they have been given supervision or instruction concerning use of the appliance by a person responsible for their safety.

Children should be supervised to ensure that they do not play with the appliance.

2. Getting Started

Welcome to your new iCoolSport Turbo. The Turbo unit is a high-power high-performance heat pump designed to chill or heat medium sized recovery pools.

Before getting started, please inspect the package contains everything and that there is no transportation damage. Contact iCoolSport for any missing parts or any damage during transportation.



All electrical and plumbing work must be completed by licensed technicians in accordance with all applicable standards and local regulations.

2.1 Basic Information

Cooling or Heating

The Turbo Range is the only product available designed specifically for efficient automatic chilling or heating of large recovery pools. Turbos can cool or heat up to 10,000 L of water from 4°C to 40°C (heating available only in Hot or Dual Temperature models).

Twin Engine Design

Each Turbo unit is a revolutionary & unique twin engine design. Two separate heat pump systems built inside a single cabinet. The Turbo units can continue to operate on one system if the other is out of service.

Smart Control and One Touch

All models feature an attractive 15 inch Full HD Touch Screen with the latest advancements in automation that can be mounted anywhere you need. The modern user interface provides fully automatic start up and operation. Just set the temp, touch START, and that's it!

Identify your Model and Series

The device model and series can be found on the main marking plate. This is found on the side of the unit below the side panel.

[Insert location of plate here]

Premium Quality

All metal work is manufactured in Australia from marine grade aluminum with a double layer of epoxy paint coating for long life durability. The 2 heat exchanger tanks are made from the highest quality Titanium tubing and can withstand all normal pool chemicals and even salt water.

The two powerful rotary compressors in each machine are manufactured by the highly respected Mitsubishi company. Electronics and systems software are designed and manufactured in Australia.

24/7 Operation

The Turbo is built to be always on and always ready every day of the year in any home or commercial applications. It can operate for a single session or around the clock for years on end automatically. The sophisticated on board computer will manage the electrical power usage to the absolute minimum needed to maintain your desired temperature while providing large savings in running costs compared to ordinary chillers.

Identify your Serial Number

The device serial number can be found on the side panel on the side of the unit.

[Insert location of serial number here]

2.2 In the Box

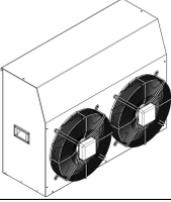
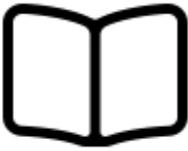
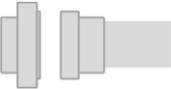
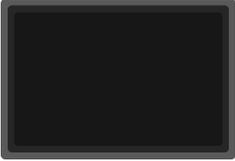
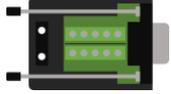
Part Name		Qty	Part Name		Qty
Turbo Unit		1	User Manual		1
40mm Barrel Union (Sometimes found already attached to the unit)		2	Control Display		1
DB9 Connector		1	8P Data Connector		1
			20m Data Cable		1

2.4 Installation

Location

The Turbo unit must be installed in an open, well ventilated area. It is recommended that the unit is installed outside, however if it is installed indoor, it must meet the minimum floor area requirements and have adequate ventilation. Failure to do so will result in degradation of performance or, in extreme cases, irreversible damage.

The location is recommended to not be within direct sunshine and exposure to the elements. If the unit is installed in a location exposed to direct sunlight and rain, it is recommended that a protective roof is installed above the unit. This will help protect the unit from debris being sucked in and degrading performance. It will also help increase performance by reducing the large amount of added heat from the sun.

The unit must be installed at a distance from the pool within the given minimum and maximums. This is to protect the unit from direct water splashing of chemically treated water and from any losses or gains in temperature through long pipe runs.

	Minimum	Maximum
Horizontal length	5m	20m
Vertical length	5m Below	5m Above

It is highly recommended that all piping, between the pool and unit, is insulated. This will also stop condensation forming on the piping. If piping is installed inside roof spaces, insulation must be used.

Every Turbo unit contains mounting bars on the base of the unit to allow it to be easily secured to wall brackets or ceiling hangers. Otherwise, it can be placed directly on a flat surface with its anti-vibration rubber feet.

Always ensure that the location picked allows for future maintenance and servicing access.

The control display must be mounted with protection from direct water splashing and rain. It is ideal to mount this indoor and away from the pool/bath. The room should have low humidity.

Clearances

The unit must be installed with the minimum clearance distances maintained. Failure to do so may result in degradation of performance or, in extreme cases, irreversible damage. Adequate spacing must also be maintained for future servicing and maintenance.

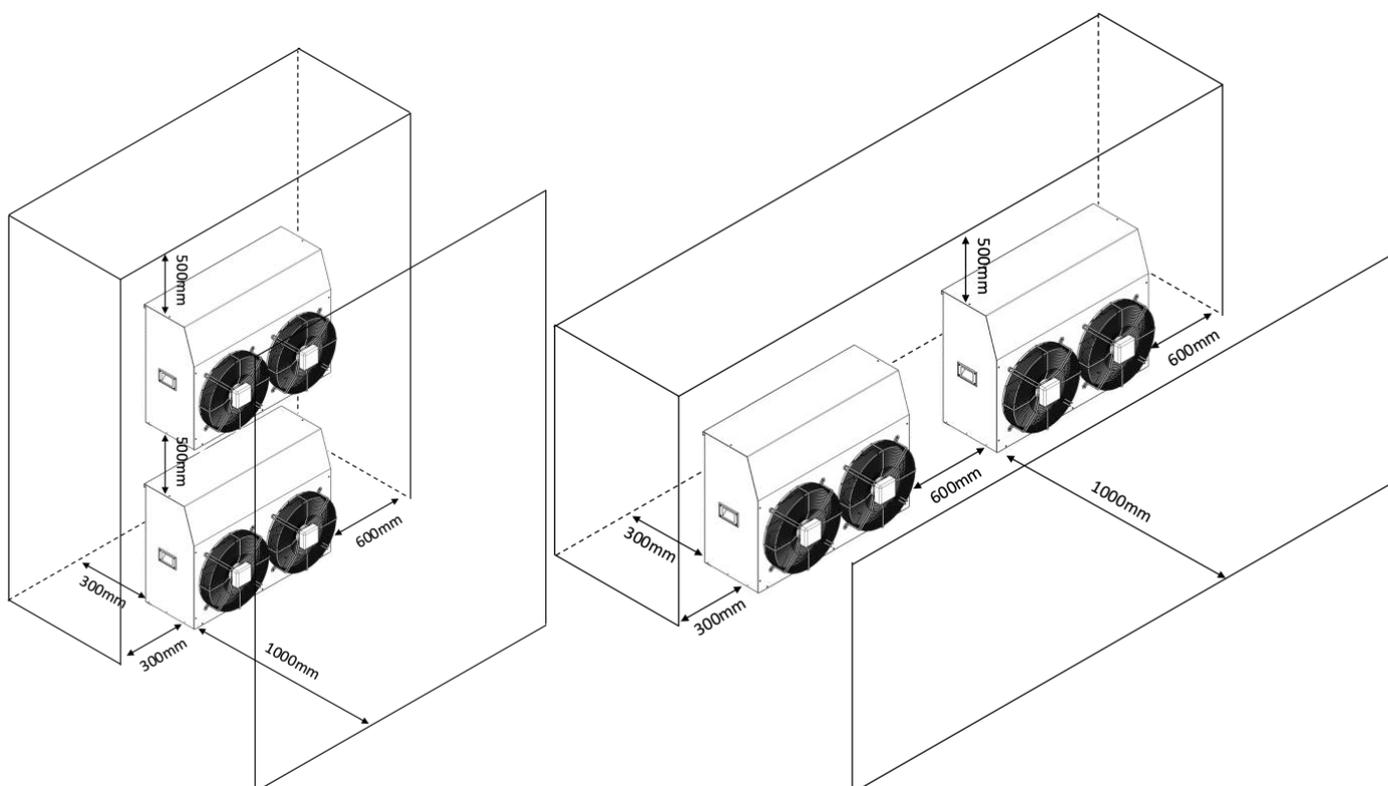
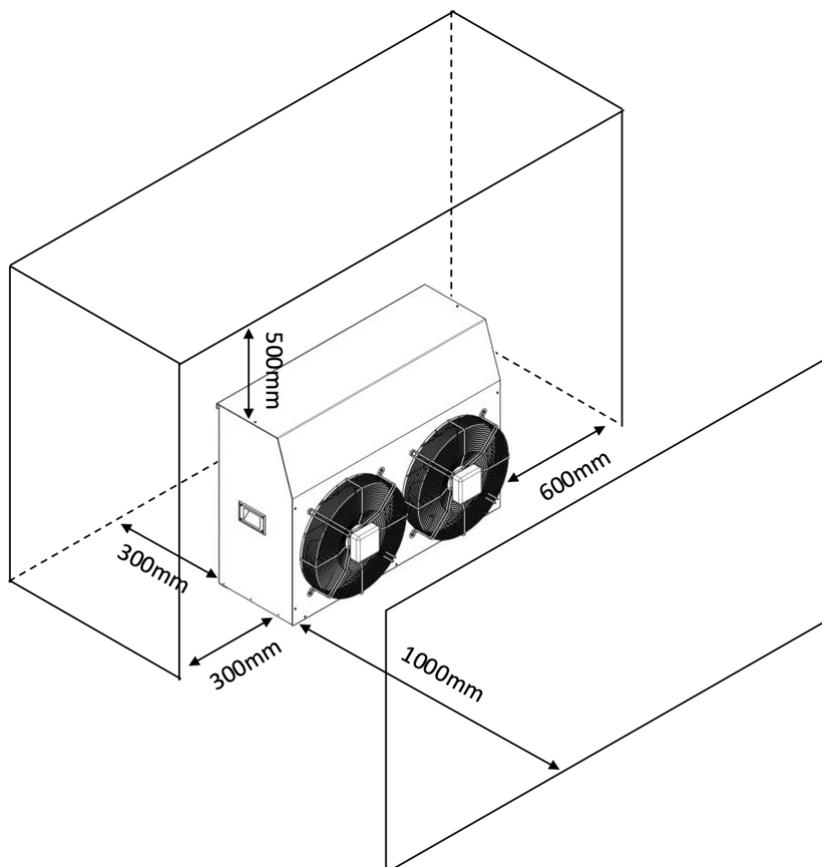

Airflow

The Turbo unit contains two 450mm fans that push through 4000cfm of air over the condensers of the unit. If the unit is installed in an enclosure area, the same amount of air must be circulated through the room to ensure that the unit can maintain full performance.

Waterflow

Every Turbo unit is equipped with a water flow switch with a preset minimum flowrate. If this flowrate is not adequate, the sensor will trigger the unit to stop to protect it from freezing the internal heat exchanger tanks.

Water flow should be maintained within a set range for optimised performance. It should always remain inside this range.

	Minimum	Maximum
Flow Rate (m/s)	60	80

Condensation

When the Turbo is set to heat the water, the condensers will become cold enough to condensate. In high humidity climates, the unit can condensate a significant amount of water. It is recommended that the unit is installed on a drip tray to capture this runoff.

Connections

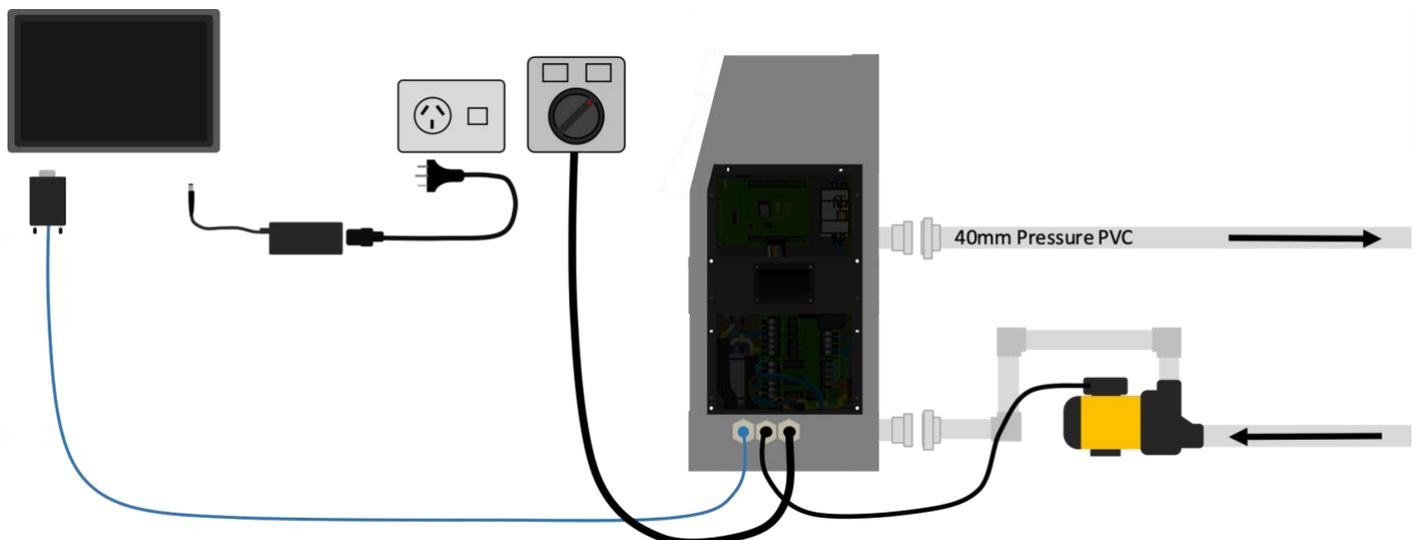

Plumbing

The Turbo unit has two 40mm PVC barrel union connections. 40mm Pressure fittings are used and 40mm pressure pipe is required for all plumbing.

If a fixed speed pump with a greater flowrate than the optimal values given is used, it is recommended that a bypass valve is installed to reduce the flowrate to the optimal. This will improve the efficiency of the unit and is a simpler option than a variable speed pump.

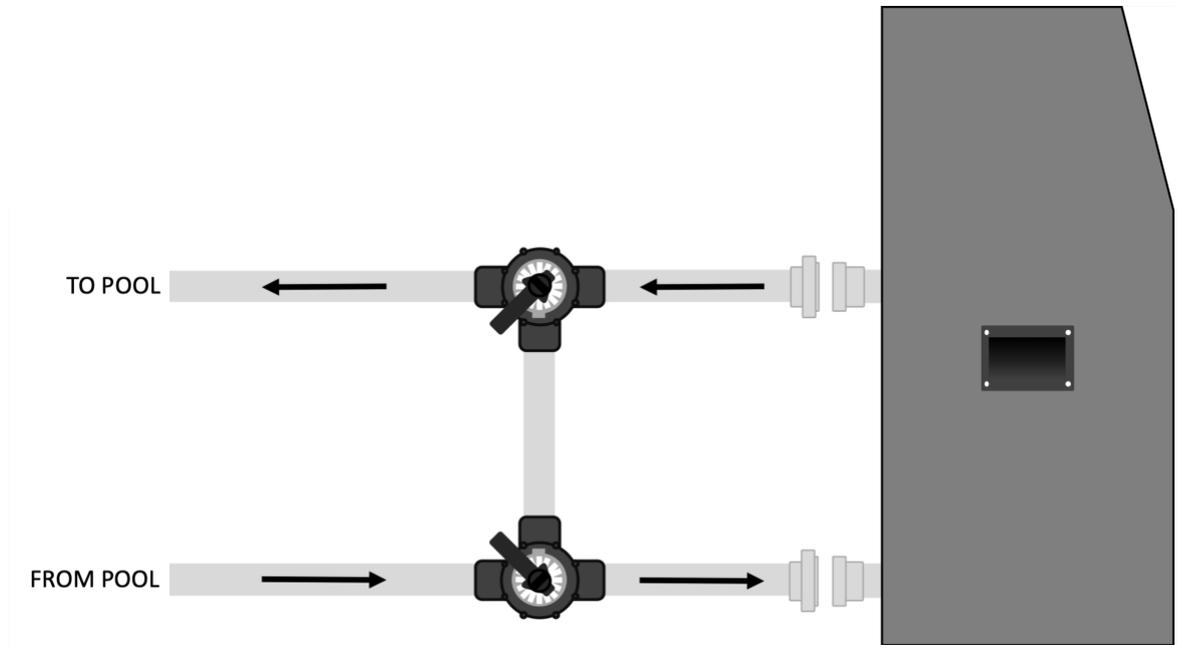

Turbo units should also be fitted with a filter inline to prevent debris from becoming stuck inside the heat exchangers and on the flow switch.

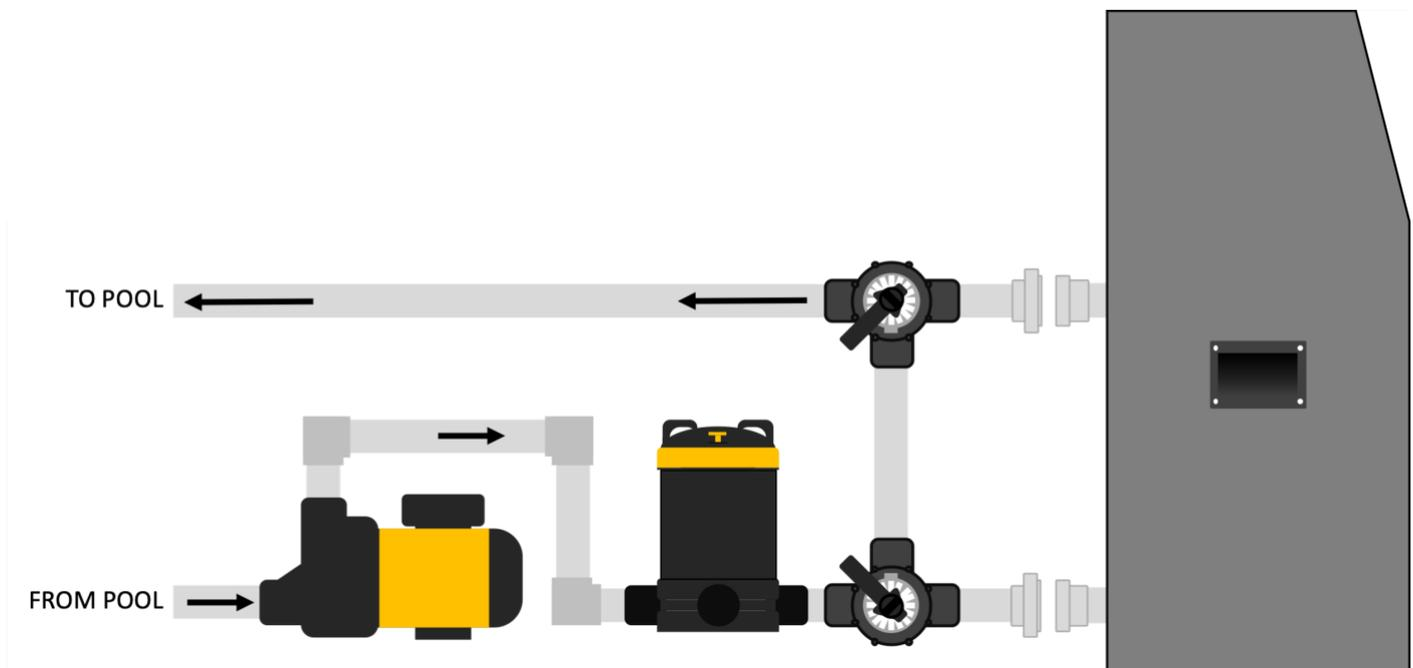

All piping must be insulated to reduce performance losses and reduce condensation forming. Filters also have a large surface area and is also recommended to be insulated.

Wiring

The Turbo unit has three basic connections that must be completed for the unit to correctly operate. The connections are main power supply, pump, and data.

All connections must be completed within local regulations and standards by a licensed electrician.

Pump power output has a max current of 10A continuous.

All wiring is complete through terminal connections behind the side panel on the unit. This side panel must be reinstalled correctly following the completion of wiring to ensure full ingress of water protection.

1. Remove the side panel of the Turbo unit, located on the right side. Eight M5x16mm button screws must be removed for the side panel to fall away. This will require a 3mm Hex key.
2. A button hardness will be connected to the side panel and can be disconnected by unplugging it from the main control board or by the connector on the button itself.
3. The supply cable can now be pushed through the right most conduit terminator located below the side panel.
4. Push the pump power cable through the middle conduit terminator.
5. Wire the active, neutral and earth wires to their respective terminals on the main power board for both supply and pump power cables.

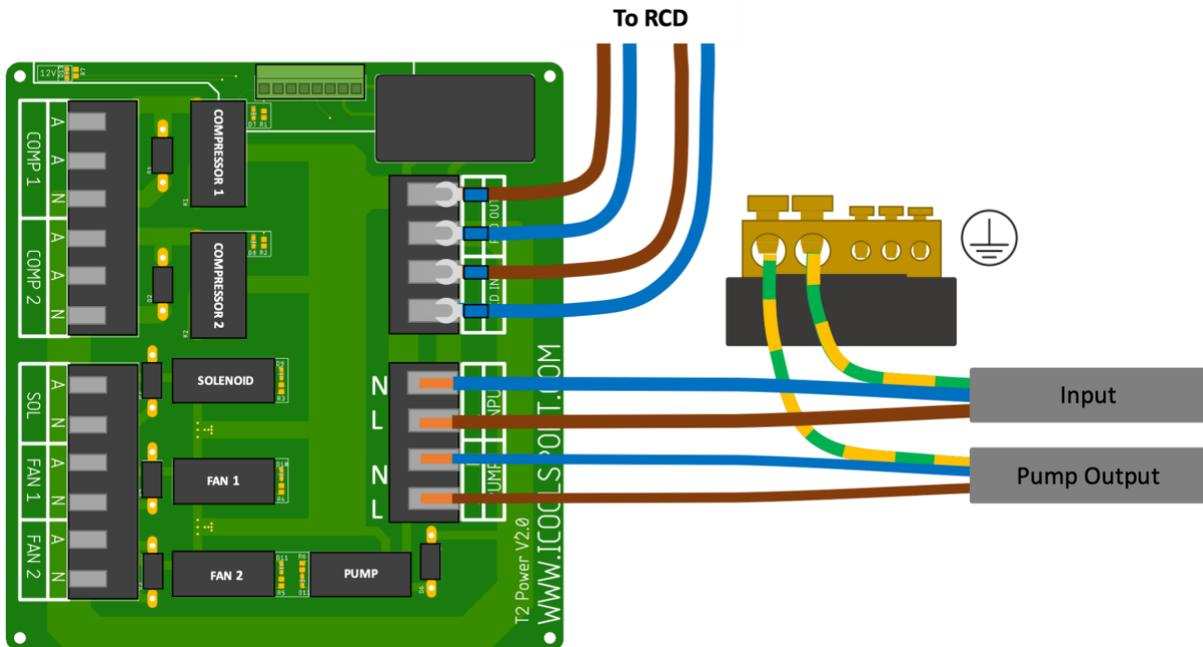

6. Push the data cable through the left most conduit terminator and wire the twisted pair to the control board.

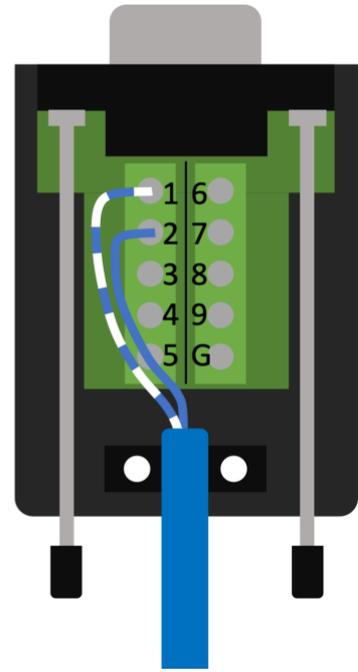
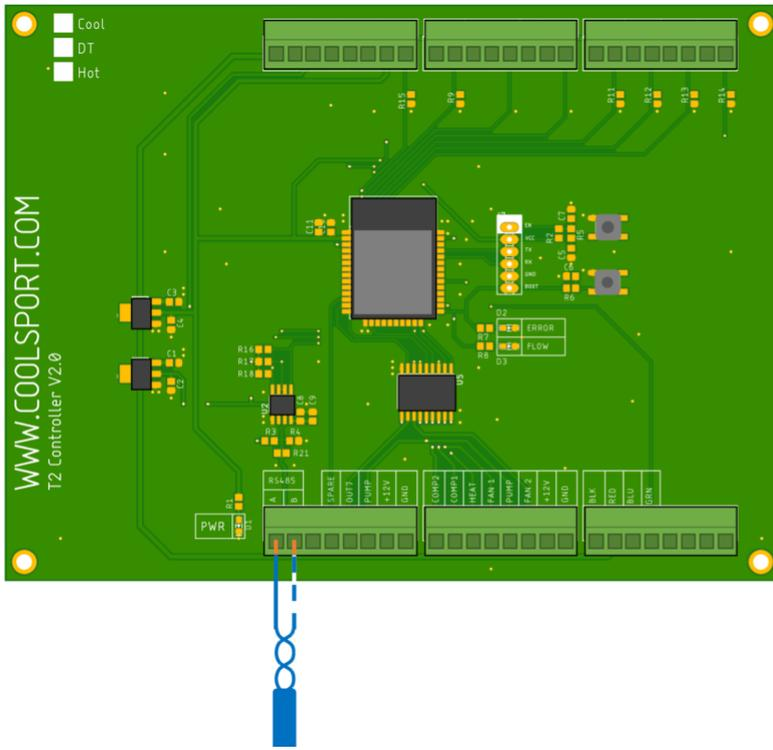

7. Reconnect the button harness and rescue the side panel. Ensure all hex screws are reinstalled and do not overtighten.

Display

Mounting

The Display is not waterproof. It must be mounted away from any direct water splashing and rain. It is ideal to mount the screen in an area or room away from water where the humidity is also low.

The display has two options for mounting. There is a mounting plate attached to the back that can be mounted to the wall, allowing the display to be removed at any time. The second option is recessed into a wall, allowing the front panel to be flush with the wall.

Connection

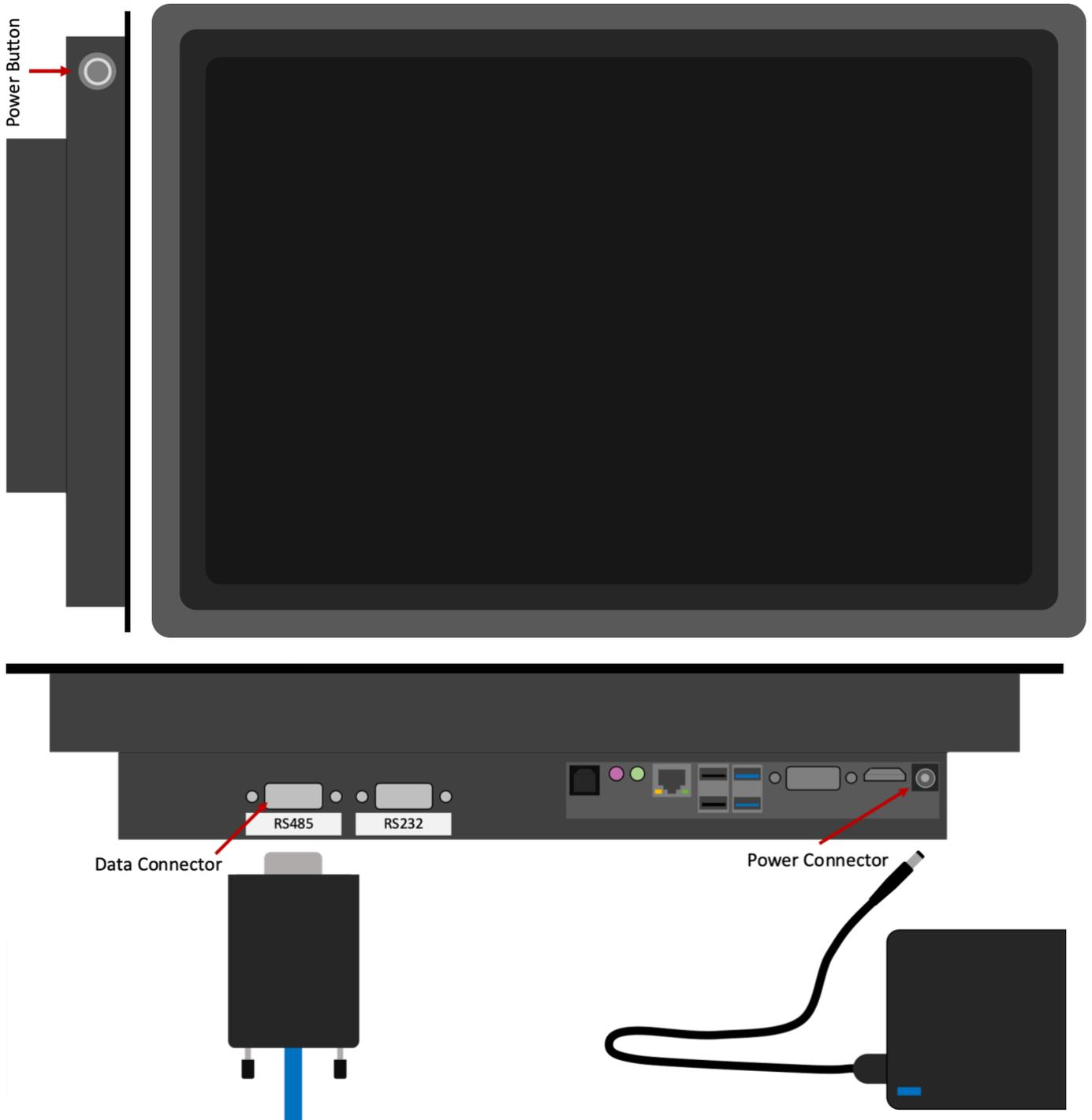

Installation Checklist

Use the checklist below to ensure everything has been completed before turning the unit on for the first time.

- Unit has been installed securely.
- Area has adequate ventilation.
- Unit has protection from direct sunlight and rain.
- Unit is within recommended distances from the pool.
- All piping has been covered in insulation.
- Minimum clearances have been met.
- The side panel has enough clearance for future access for servicing.
- Unit has adequate drainage for condensation.
- Plumbing contains a bypass valve for large flowrate pumps.
- Main power and pump have been wired.
- Data connection has been terminated.
- Screen has been mounted and connections have been made.
- Screen is a water and humidity free area.

2.4 First Start

Before starting the unit for the first time, ensure that the installation checklist has been completed. Then power the unit on and ensure that the unit's internal lights turn on (located behind the side panel on the right side of the turbo unit).

Ensure all valves are open anywhere along the loop between the pool and the unit. This includes opening the bypass valves fully if they have been installed.

1. Navigate to the settings menu on the main display and locate the manual pump setting.
2. Turn the pump setting on to engage the pump and allow the system to prime.



If the pump does not cycle water, ensure the system does not contain any air locks. It might be necessary to manually prime the pump.

3. Check the system for leaks.
4. With the manual pump still on, navigate to the main menu and set the target temperature.
5. Start the unit.

During the start up sequence, check that each component of the system correctly starts. This can be achieved by listening. The system will always complete the start up of each component in the same order.

Timing	Component
Start button pressed.	Pump
Water Verification successful.	Reverse Valves (if dual temperature or hot version)
~1s	Fans
~10s	Compressor 1
~40s	Compressor 2

Note: Components start in order from top to bottom.

Allow the system to run for some time and note the pool temperature. On first start, the system requires some time to show an accurate reading for the temperature of the water. Then ensure that over the next hour, the pool temperature changes from the starting temperature.

If any errors occur during the first start, consult the troubleshoot section to resolve.

3. Technical Data

3.1 Specifications

Specification		Unit	Model		
			Cool	DT	Hot
Voltage		V	220-240	220-240	220-240
Frequency		Hz	50/60	50/60	50/60
Power		kW	3.77		
Current*1		A	15.72		
Airflow		cfm	4000		
Noise	@ 1m	dBA	-		
	@ 3M		58		
Dimensions (L x W x H)		mm	1070 x 510 x 835		
Water connection type		mm	40 (Pressure)		
Weight		kg	122		
Operating Range	Air Temperature	Min	0	0	0
		Max	65	65	65
	Water Temperature	Min	4	4	-
		Max	-	40	40
Refrigerant (per compressor)		Type	R290		
		Charge	g		
Refrigerant Oil (per compressor)		Type	ATMOS NM56M or SUNISO 4GDID		
		Amount	cm ³		
Capacitor		uF	45		
Optimal flow rate		L/min	66	66	66
Built-in Safety Switch (RCBO)		-	25A RCBO 30mA trip current		
Notes: Specifications are based on ____ - *1: Based on pump output connected to a Davey QB035-AMP (1.6A run current)					

3.2 Dimensions

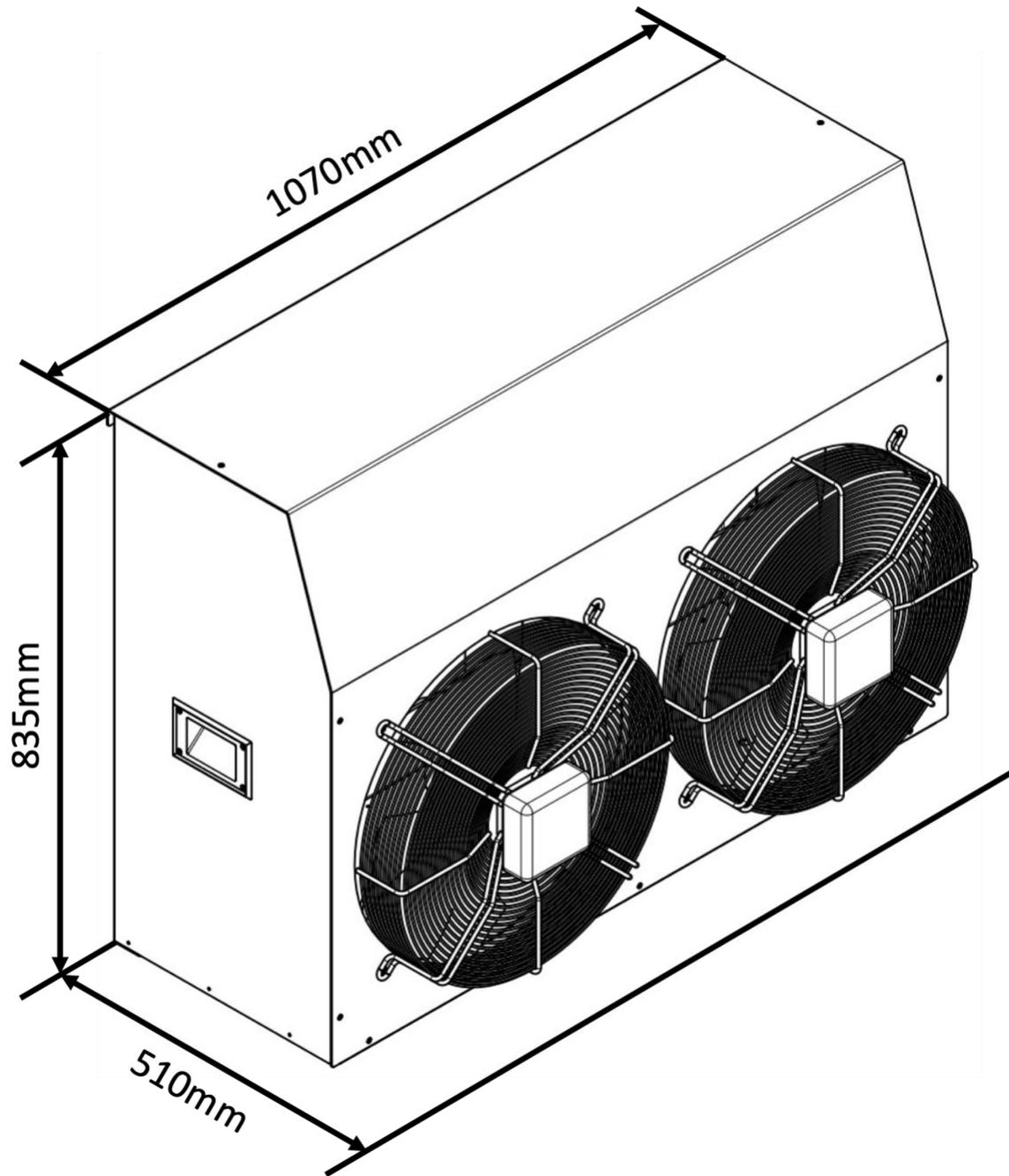

5. Operation

5.1 Controller

Functions

Main Menu

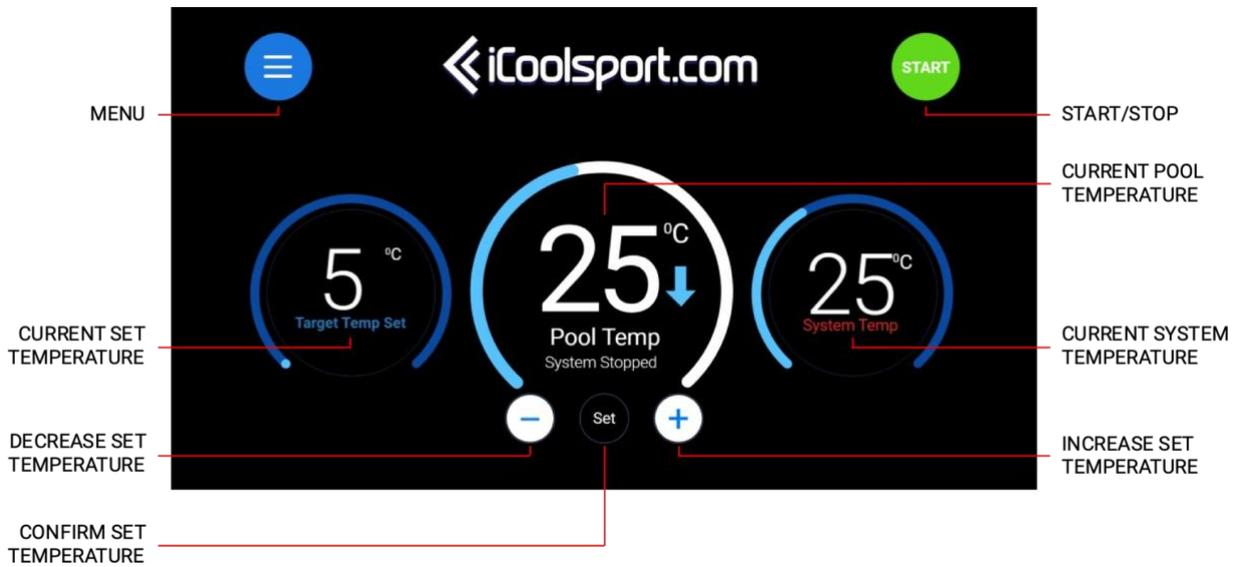

Icon	Function	Description
	Menu	Button to open the menu tab to navigate to other pages.
	Start/Stop	Button to start or stop the chilling or heating of the unit, to the current set temperature.
	Current set temperature	Displays the current set target temperature.
	Current pool temperature	Displays the current pool temperature. Alternative function will display the new target set temperature.
	Current system temperature	Displays the current system temperature.
	Decrease set temperature	Button to decrease the current set target temperature.
	Increase set temperature	Button to increase the current set target temperature.
	Confirm set temperature	Button to confirm the new set target temperature.

The main menu is the first screen that will be shown when the display is turned on. This menu allows full control of the system, such as setting the target water temperature, and the system can be started or stopped.

Setting Target Temperature and Starting the System

Increase or decrease the set temperature to the desired target temperature by pressing the or buttons.

Once at the desired temperature, press to save the target temperature.

“Current Set Temperature” will now display the new desired target temperature.

Press  to start the system.

The system will now attempt to start and will cool/heat to the set target temp.

Changing the Target Temperature while System in Operation

Increase or decrease the set temperature to the desired target temperature by pressing the  or  buttons.

Once at the desired temperature, press  to save the target temperature.

“Current Set Temperature” will now display the new desired target temperature.

The system will now cool/heat automatically to the new target temperature.

Stopping the System

Press  to stop the system.

The system will safely stop.

Settings Menu

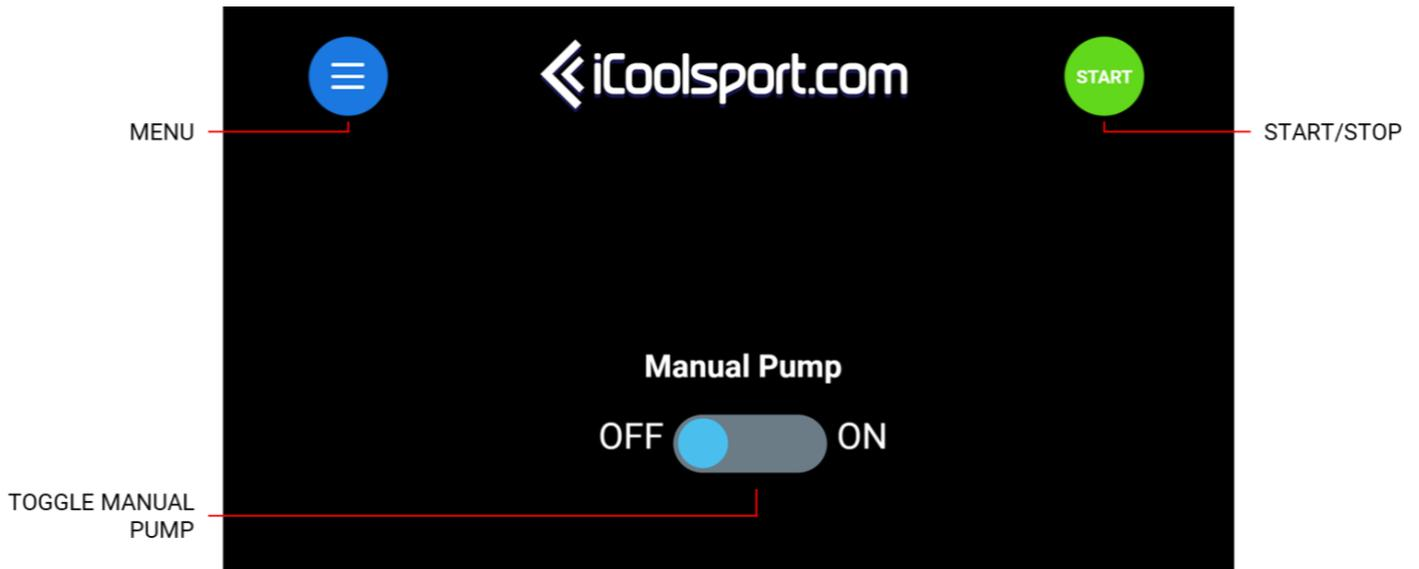

Icon	Function	Description
OFF  ON	Toggle Manual Pump	Toggle pump on and off when unit is in the off state.

The settings menu contains user settings to configure the Turbo unit.

The manual pump setting can be used to prime the system. This option will turn on the pump while the system is in the off state and will continue to run until it is turned off again or the system is started from the start button.

Timer Menu

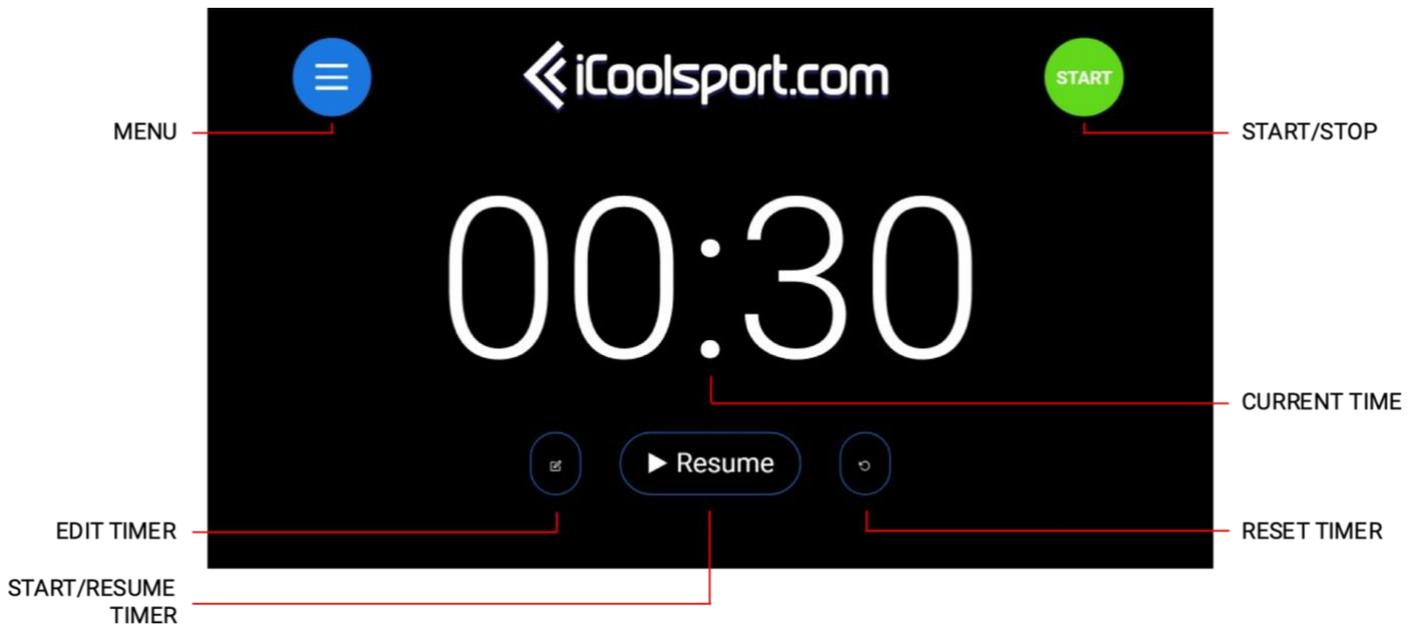

Function	Description
Current time	Display for the current timer time.
Edit Timer	Button to change to timer config menu to change the timer config.
Reset Timer	Button to reset the current timer back to start time.
Start/Resume Timer	Button to start/resume current timer.

Timer Config Menu



Function	Description
Edit Minutes	Button to increase/decrease the current minutes.
Edit Seconds	Button to increase/decrease the current seconds.
Countdown Time	Display to show current set countdown time.
Change Over Time	Display to show current set change over time.
Save Timer	Button to save new config.

Set Pin Menu

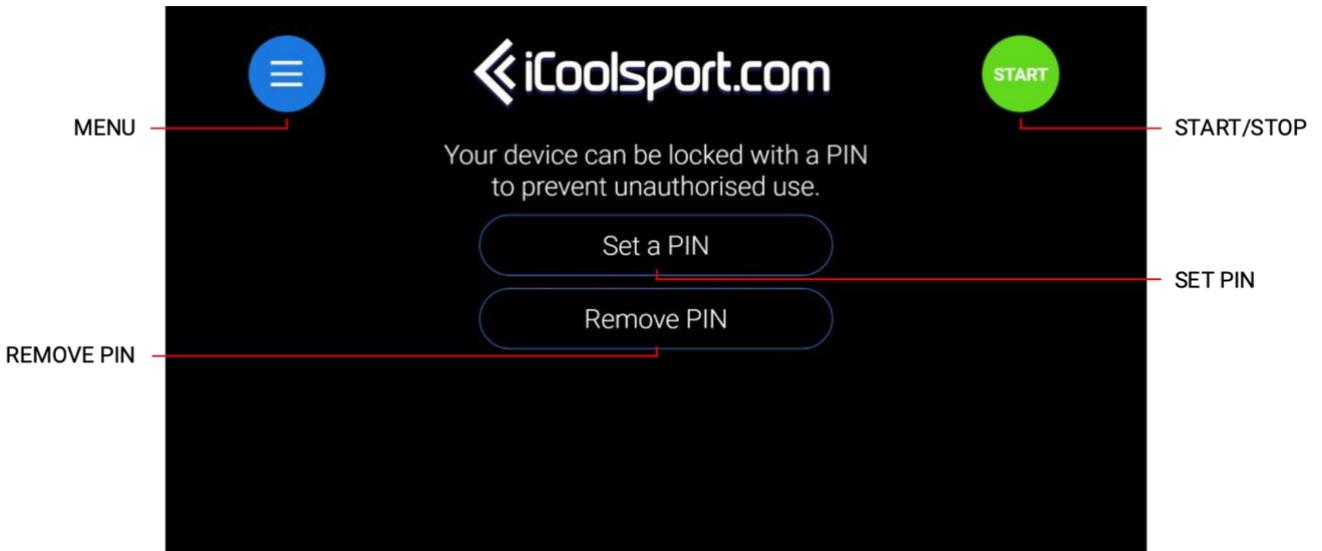

Function	Description
Set Pin	Button to start the set pin sequence.
Remove Pin	Button to remove the set pin.

A pin can be set to lock the display. When any functions are performed, the display will request the pin to be entered to complete the input. The pin can be removed using the same pin code. If the pin is forgotten, please contact iCoolSport support on how to remove the pin.

When setting a pin, a menu will open and will request the pin to be entered. Enter 4 digits to set the pin.

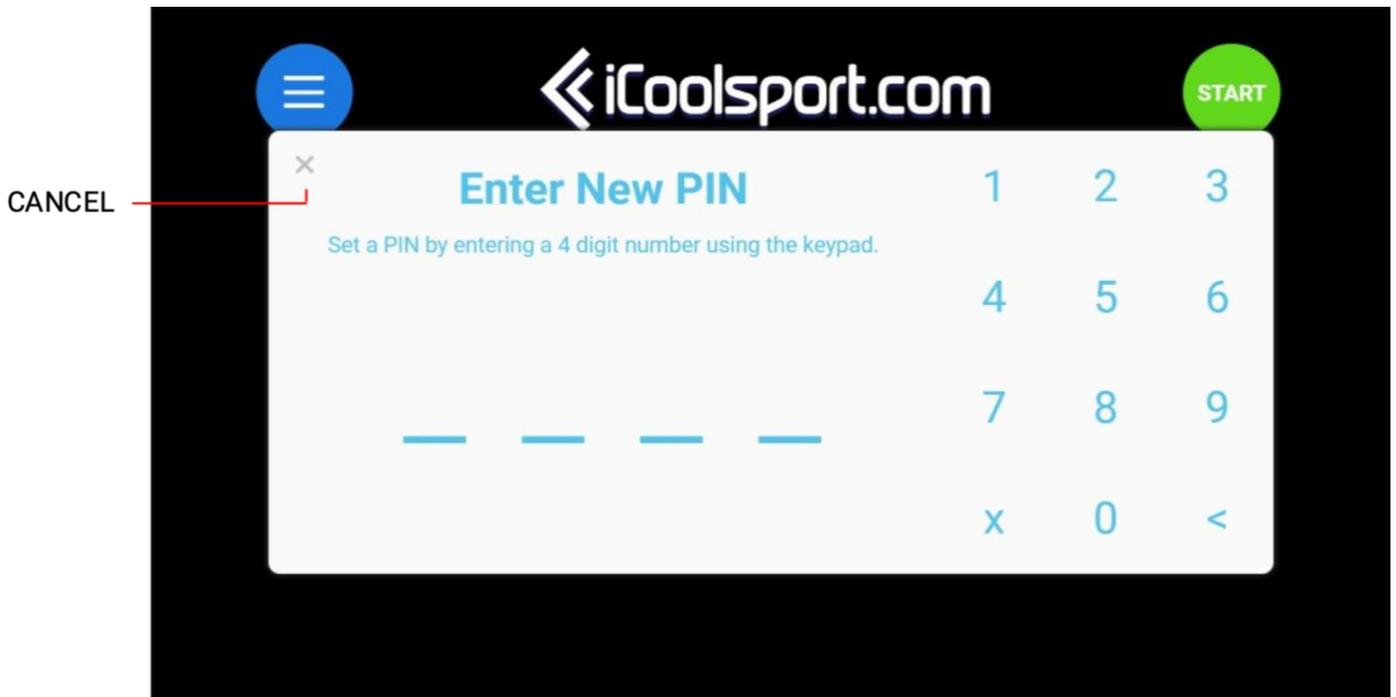

Function	Description
Cancel	Button to cancel setting a pin.

To remove the current set pin, simply press “Remove Pin”. A menu will appear to enter the current set pin. Enter the correct set pin and a dialog will prompt you to confirm this action. If the current set pin is forgotten, please contact iCoolSport Support on how to remove the pin.

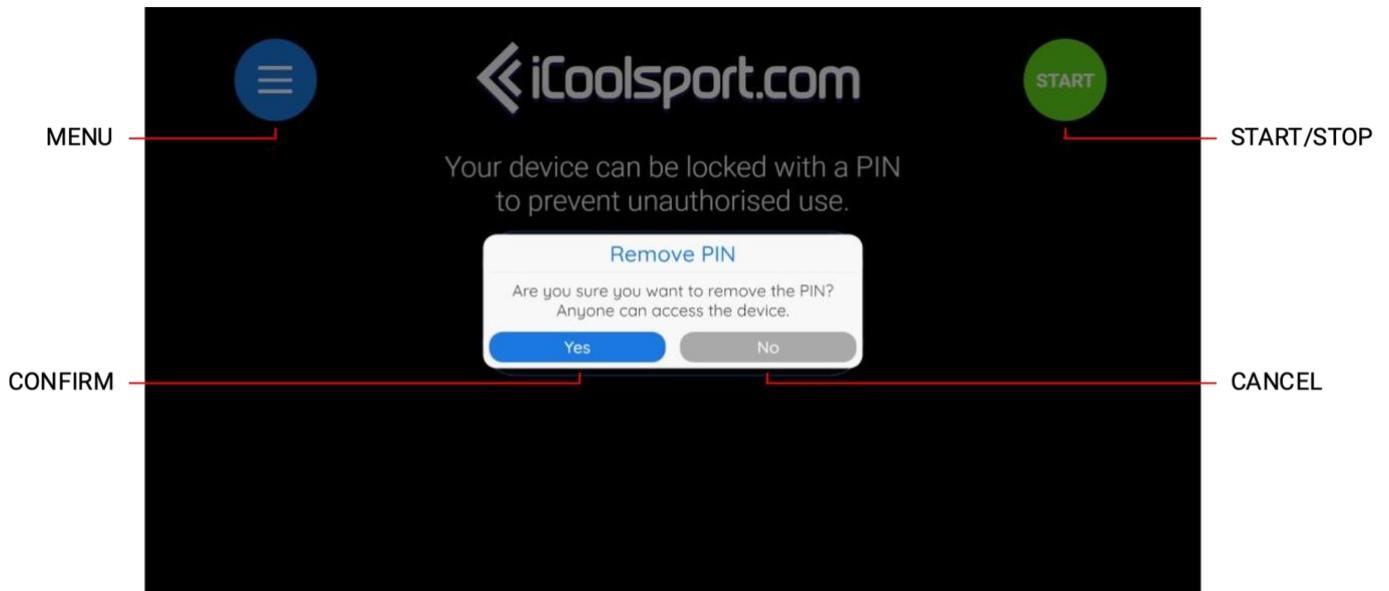

Function	Description
Confirm	Button to confirm removing the pin.
Cancel	Button to cancel removing the pin.

Device Information Menu



Function	Description
Device ID	Device ID of the unit.
Model	Model of the unit.
Unit	Unit.
Version	Software version of the display.

The device information menu is useful for finding information about your Turbo unit.

Disconnected Menu

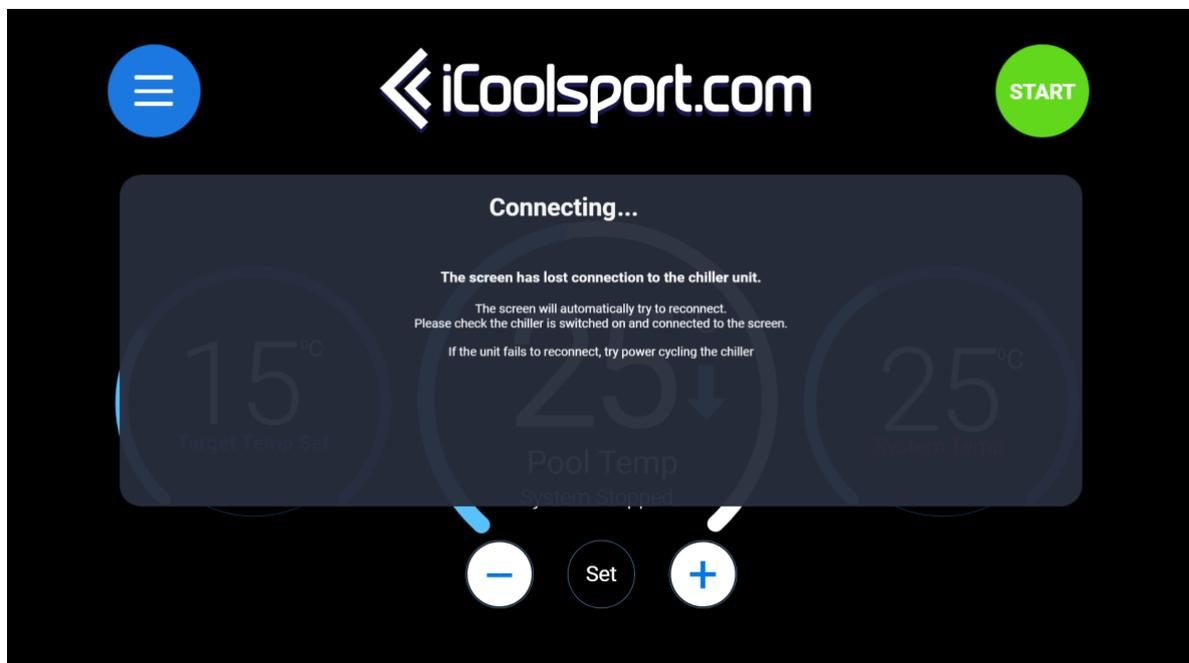

The disconnected menu will appear when the display is unable to make a connection to the Turbo unit. Consult troubleshooting to resolve this error.

5.2 Unit

The main Turbo unit contains two points of operation. From the unit, a single button can be used to start the unit without the display connected and the safety switch can be operated.

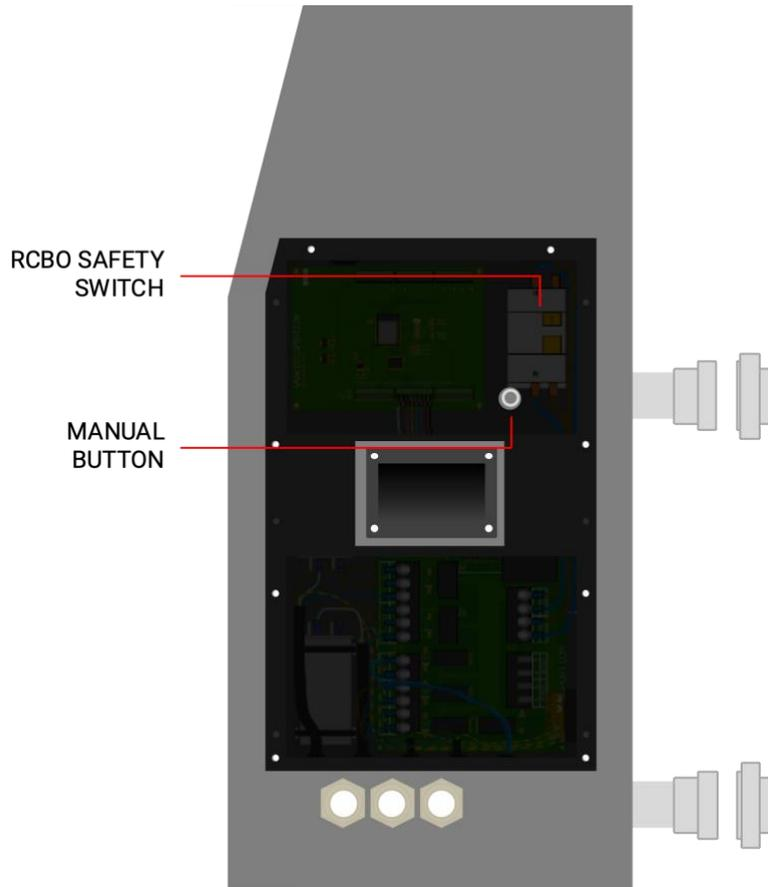

Functions

Manual Button

The manual button can be used to start/stop the unit without the display connected.

1. Hold the button in for 10 seconds, or until the LED light starts to blink, to start the unit.
2. The unit will now go through the startup sequence. The LED light will change from blinking, to solid once it has verified water flow.
 - a. If this does not occur, the unit will attempt to try resolve the issue. If this fails, the LED light will turn off and the problem will need to be resolved before attempting again.
3. Once the LED light turns solid, the start up sequence will complete and the unit will cool/heat the water to the last set temperature.

To stop the unit, hold the button again, until the LED light turns off and the system audible stops.

RCBO Safety Switch

All Turbo units should be wired to a dedicated RCBO for protection. However, each unit does also include a secondary safety switch to protect it from over current and earth faults.

If a fault occurs and this switch trips, please consult a refrigeration technician or iCoolSport support to resolve the issue before turning the safety switch back on.

6. Maintenance

It is recommended that the unit is checked yearly to ensure that it is operating at full performance. In installations close to the ocean or corrosive environments, this should be done more frequently at half yearly, minimum.

Water quality management is subject to use load and the amount of water being used. It is recommended to contact your local pool shop for advice on how to treat the water as this will need to be done a regular basis.

Disconnect all power to the unit or display while cleaning.



Warning: Isolate and disconnect all power before opening unit for servicing.



Warning: relevant maintenance must be performed by all relevant certified trades.

6.1 Turbo Unit

Paint

The turbo unit is constructed with marine grade aluminium that is powder coated to help protect the unit.

The paint will maintain in good condition if it is regularly looked after and is not placed in an environment that advances the degradation.

Avoid areas that will be exposed to erosive winds, such as ocean winds, and areas with direct and constant UV exposure.

To clean the paint the following can be performed.

1. Use water and a cloth to remove loose debris.
2. Use a mild detergent and a non-abrasive cloth/brush to clean the surface. For tougher marks, use only solvents such as Isopropyl alcohol. Never use aggressive solvents.
3. Wash unit with clean water.

Heat Exchangers

All systems should be fitted with a filter to reduce the possibility of debris getting stuck inside the heat exchangers. However, sometimes the filter may not be sufficient to keep the titanium coils and pipes from building a coating of grease and oils from users.

For best advice on maintaining a clean system, consult your local pool shop.

Condensers and Cabinet

Cleaning the cabinet and condensers is vital for continual performance. If too much dirt and debris become stuck on the condensers, it is likely to lead to reduced airflow.

The unit must be opened in order to gain access to both sides of the condensers. This also allows a perfect time to remove all loose debris inside the cabinet.

1. Remove the eleven M5x10mm Button head screws with a 3mm Hex key.

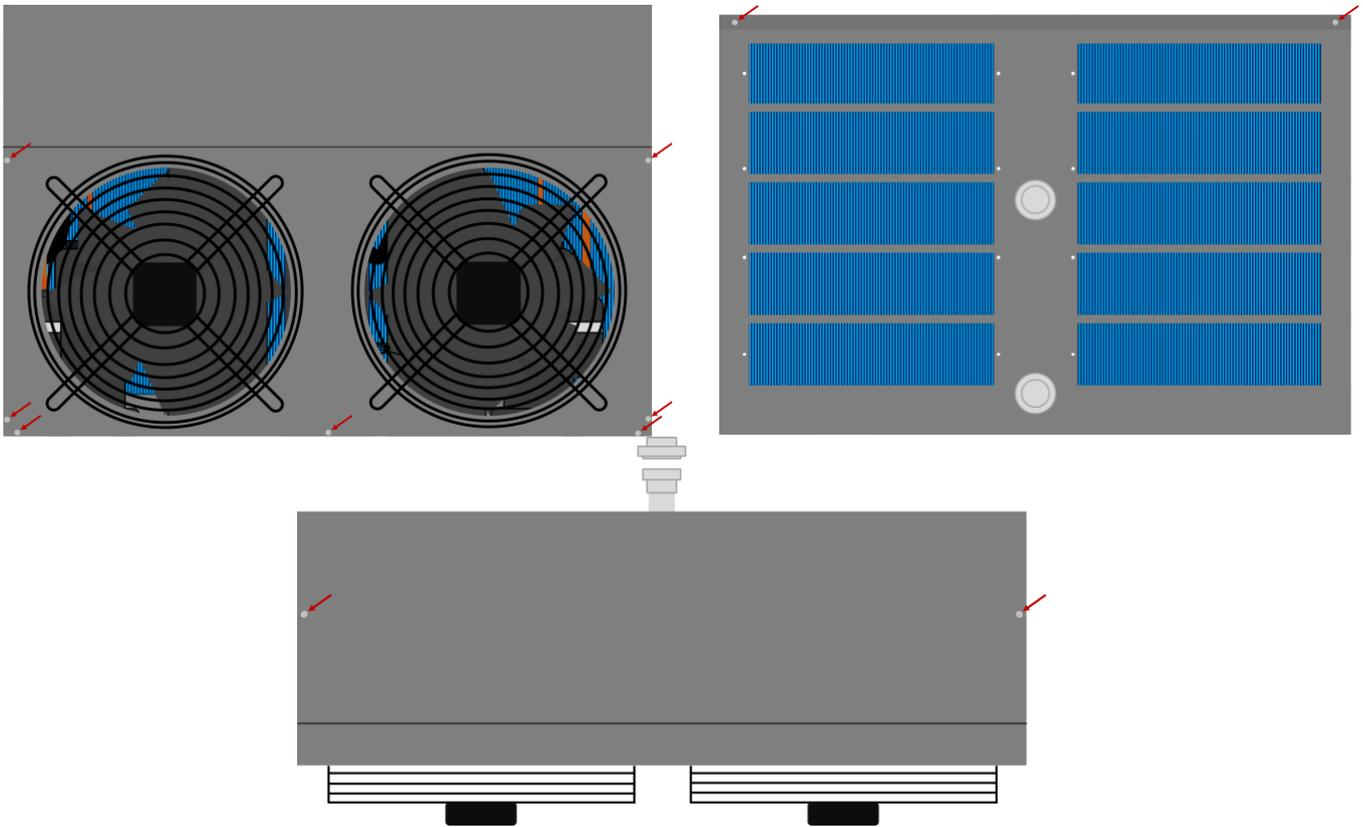

2. Pull the cover up and forward.
3. Disconnect the two fan cables at the inline connectors.
4. Place cover on a flat surface without resting any weight on the fan blades.

To clean the cabinet, use a vacuum or leaf blower to remove large debris. For dust, use a small brush or duster.

The condensers can be cleaned with water or a spray coil cleaning aerosol.

1. Start by spraying the condensers with water to remove dust and debris.
2. If the condensers still contain grease, oil or other debris, use an aerosol coil cleaning spray. Follow the directions of the specific spray used.
3. Rinse the cleaning agent off the condensers.
4. Allow the unit to dry.
5. Ensure that the fan cables do not contain any water in the pins and then reattach both cables.
6. Mount cover and reattached screws.

6.2 Display

Screen

The screen should only be cleaned with distilled water. Do not use soaps or solvents as this may damage the coating on the display.

1. Use a cloth to wipe the display and remove any dust and debris.
2. Wet a cloth with distilled water and wipe in a sweeping motion from top to bottom, and side to side using light pressure.
3. For any stubborn marks, an LCD display cleaning solution can be used. Use a small amount on a clean cloth and wipe in sweeping motions again.
4. Ensure all water has been dried before turning display back on.

Case

The case can be cleaned with a microfibre cloth, compressed air, and isopropyl alcohol. Never use water on the case as it may find its way to the internal circuit board and cause permanent damage.

1. Remove dust from the case using a clean microfibre cloth. Compressed air can also be used to blast dust in the connectors.
2. Use isopropyl alcohol on a clean cloth to wipe down case.
3. Allow time for the isopropyl alcohol to dry before turning the display back on.

6.3 Transportation

Transport the unit in an upright position. If unit is laid over, please allow at least an hour after standing upright before starting the unit again.

7. Troubleshooting

Problem	Reason	Solution